



International Rescue Committee Sudan

Request for Proposal (RFP) For

CONSTRUCTION OF STAND PIT LATRINES AND IMPROVED BATHING SHELTERS IN TUNAYDBAH CAMP.

Ref: # IRC/SDN/TENDER/2023/04

Planned Timetable	
Issue Request for Proposal	<i>17 October 2023</i>
Questions from Suppliers due date	<i>22 October 2023</i>
Answers to Suppliers questions due date	<i>23 October 2023</i>
Bid submission due date	<i>30 October 2023</i>
Suppliers return signed Intent to Bid forms due date	<i>30 October 2023</i>
Bid Opening and Evaluation date	<i>1st November 2023</i>
Suppliers visit if applicable	<i>2nd November 2023</i>
Award of Business	<i>15th November 2023</i>
Contracts start	<i>30th November 2023</i>

Table of Content

	Pages
I. INTRODUCTION	3
1. <i>The International Rescue committee</i>	3
2. <i>The Purpose of this Request for Proposal (RFP)</i>	3
3. <i>Cost of Bidding</i>	3
II. THE BIDDING DOCUMENTS:	3
4. <i>The Bidding Documents</i>	3
5. <i>Clarification of Bidding Documents</i>	4
III. PREPARATION OF BIDS:	4
6. <i>Language of Bid</i>	4
7. <i>Documents Comprising the Bid</i>	4
9. <i>Bid Currencies</i>	5
10. <i>Document Establishing Goods Eligibility and Conformity to Bidding Documents ...</i>	5
11. <i>Bid Security</i>	6
12. <i>Period of Validity of Bids</i>	6
13. <i>Format and Signing</i>	6
IV. SUBMISSION OF BIDS	6
14. <i>Submission and Marking of Bids:</i>	6
15. <i>Modification and Withdrawal of Bids</i>	7
V. BID OPENING AND EVALUATION	7
16. <i>Preliminary Examination</i>	7
17. <i>Evaluation and Comparison of Bids</i>	7
18. <i>Contacting the Purchaser</i>	8
19. <i>Notification of Award</i>	8
VI. CONTRACTING	9
20. <i>Contract award and notification</i>	9
21. <i>Warranty</i>	9
22. <i>Inspection</i>	9
23. <i>Price Schedules and Location</i>	9
24. <i>Service or consultant agreements</i>	9
25. <i>Disclaimer</i>	9
26. <i>Ethical Operating Standards</i>	Error! Bookmark not defined.

A. INTRODUCTION

1. *The International Rescue committee*

The International Rescue Committee, hereinafter referred to as “the IRC”, is a non-profit, humanitarian agency that provides relief, rehabilitation, protection, resettlement services, and advocacy for refugees, displaced persons and victims of oppression and violent conflict.

2. *The Purpose of this Request for Proposal (RFP)*

It is the intent of this RFP to secure competitive proposals to select Contractor(s) for the International Rescue committee, Sudan Country Program to do Construction at various sites as listed in the table below.

Item No.	DESCRIPTION
Lot A	Construction of Ten Pit Latrine of two stances Tunaydbah Camp.
Lot B	Construction of Ten Bathing shelters Tunaydbah Camp.

The market is divided into **2 Lots** as per above list

Bidders can apply for one or all Lots. The evaluation for the two lots will not be done uniformly. All qualified and interested Suppliers are invited to submit their proposals for one or all Lots.

Bidders shall be domiciled in and shall comply with all Government Regulations to operate in Sudan. Bidders shall be regular taxpayers and shall furnish a copy of their operating license/certificate of registration valid for the fiscal year 2022/23. Bidders shall not be under a declaration of ineligibility for corrupt or fraudulent practices.

3. *Cost of Bidding.*

The Bidder shall be responsible for all costs associated with the preparation and submission of its bid, and IRC hereinafter referred to as “the Purchaser”, will in no case be responsible or liable for those costs, regardless of the conduct or outcome of the bidding process.

B. THE BIDDING DOCUMENTS:

4. *The Bidding Documents*

The Bidder is expected to examine all instructions, forms, terms, and specifications in the bidding documents prepared for the selection of qualified contractor. Failure to furnish all information required as per the bidding documents or to submit a bid not substantially responsive to the bidding documents in every respect will be at the Bidder’s risk and may result in bid rejection.

5. **Clarification of Bidding Documents**

A prospective Bidder requiring clarification of the Bidding Documents may notify the Purchaser in writing at (SU-KhartoumProcurement SU-KhartoumProcurement@rescue.org). The request for clarification must reach the purchaser not later than **22 October 2023**. The Purchaser shall respond by e-mail providing clarification on the bid documents no later than **23 October 2023**. Written copies of the Purchaser's response (including an explanation of the query but without identifying the source of inquiry) shall be communicated to all prospective Bidders which express an intention to submit bids.

C. PREPARATION OF BIDS:

6. **Language of Bid**

The Bid and all related correspondence and documents exchanged between the Bidders and the Purchaser shall be written in English. Any printed literature furnished by the Bidder and written in another language shall be accompanied by an English translation of its pertinent passages, in which case, for purposes of interpretation of the bid, the English version shall prevail.

7. **Documents Comprising the Bid**

The submitted bid shall include the following information. Failure to provide all requested information or to comply with the specified formats may disqualify the Bidder from consideration.

Eligibility documents that will be checked before technical evaluation (Preliminary Evaluation)

- *Profile of the company*
- *Certified or color copy of trading license.*
- *Certified or color copy of income tax clearance*
- *Copy of VAT Registration Certificate (If applicable)*
- *Registered Power of Attorney (if addressed to IRC should be Original and if general should be certified by Register of Companies or be a color copy)*
- *Certificate of Business registration*
- *Memorandum and Article of Association*
- *Intent to Bid filled, signed & stamped Annex F*
- *Vendor information form filled, signed & stamped Annex D*
- *IRC Conflict of Interest and supplier code of conduct filled, signed & stamped – Annex E*

Technical (Envelop/Folder)

- *Tenderer's Programme of works*
- *Tenderer's Key Personnel with CVs and academic documents*
- *Tenderer's machinery with evidence of ownership or lease agreement with the owner of the machinery.*
- *Evidence of experience i.e recommendation letter or Certificate of Completion, 5 certificate of completions shall be provided as mentioned in clause 17,*
- *Certificate of Site Inspection Annex H (and this document RFP) – duly endorsed (signed and stamped) by IRC representative at the respective sites (IRC Field Coordinator for Base camp construction sites and Health Center In-charge at Health Center construction sites and WASH Engineer.)*

- Evidence of ownership of the equipment (Vehicle Receipts or Registration book) or lease agreement
- Technical BoQs filled, signed & stamped.
- Technical drawings signed & stamped- Annex C
- Schedule of Form – Latrines and bathing shelters filled, signed & stamped.
- Schedule of Form Annex G– filled, signed & stamped.

Financial Envelop

- Annex A: - Tenderer's Financial Offer Priced Bills of Quantities.
- Certified audited books of accounts for the past three years
- Signed and stamped letter to IRC (Purchaser) by the contractor that 100% or more of the work shall be completed using contractor's own resources.
- Last three months Bank statement- June, July and August 2023
- Capabilities of getting loan-letter from a financial institution if contractor doesn't have resources of its own to do the work.
- Other important documents bidder feels need to be attached to support his/her bid.

8. Bid Prices.

The Bidder shall clearly indicate the unit price of the items in the Bill of Quantities (BoQ). All unit prices shall be clearly indicated in the space provided in the BoQ, and all unit prices quoted in the RFP response shall be agreed to be in effect for a minimum of twelve (12) months beginning on the date when the contract is executed, with the exception of products or services which are subject to significant and unavoidable market forces which prevent this, in which case the Bidder shall describe and justify the driver(s) of potential price fluctuation during the first twelve (12) months of the agreement. The Bidder shall sign and stamp the Bill of Quantities (BoQ)/price schedule with the Bidding Company's seal where feasible.

9. Bid Currencies

All financial rates and amounts entered in the Bid Form and Bill of Quantities/Price Schedule and used in documents, correspondence, or operations pertaining to this tender shall be expressed in Sudanese Pounds.

10. Document Establishing Goods Eligibility and Conformity to Bidding Documents

Pursuant to Clause 7, the Bidder shall furnish, as part of its bid, documents establishing the eligibility and conformity to the Bidding Documents of all goods and services, which the Bidder proposes to supply under the Contract.

The Documentary evidence of the goods and services' conformity to the Bidding Documents may be in the form of technical specifications, literature, drawings, data (tables, graphs etc.), and shall furnish:

- A detailed description of the goods' essential technical and performance characteristics.
- A clause-by-clause commentary on the Purchaser's Technical Specifications demonstrating the goods and services' substantial responsiveness to those specifications or a statement of deviations and exceptions to the provisions of the Technical Specifications.

The Bidder may propose alternate standards, brand-names and/or catalogue numbers in its bid, if it demonstrates to the Purchaser's satisfaction that the substitutions are substantially equivalent or superior to those designated in the Technical Specifications.

11. Bid Security

The bidder shall provide the following bonds.

- Bid Bond: The bidder shall provide an equivalent of 10% of the Bid value. Enclose the bid bond in your proposal.
- Performance bond, as a security from a reputable insurance company or bank to guarantee satisfactory completion of a project by the bidder. The performance bond shall be equivalent to 10% of the contract value. This will be issued to IRC by the selected supplier before signing the contract. The performance bond will replace the bid bond when the bid is acknowledged, and a contractor is selected to execute the work.
- The bidder will provide Retention bond equivalent to 10% of the contract value from a reputable insurance company in case the bidder wants 100% payment. This will be provided after completion of work.
- Any bidder who wishes to get 30% advance payment will have to provide, an advance payment guarantees equivalent to 30% of the contract value after award of contract and reasonable mobilization at site.

12. Period of Validity of Bids

Bids shall remain valid for 90 working days after the date of bid opening prescribed by the Purchaser. A bid valid for a shorter period may be rejected by the Purchaser as non-responsive.

In exceptional circumstances, the Purchaser may request the Bidders to extend the period of validity. The request and the responses thereto shall be made in writing by letter or e-mail. A bidder agreeing to the request will not be required nor permitted to modify his bid.

13. Format and Signing

The original bid shall be signed by the Bidder or by a person or persons authorized to bind the Bidder to the contract. Financial proposal pages of the bid shall be initialed by the person or persons signing the bid and stamped with the Bidder's company seal.

Interlineations, erasures, annotations, or overwriting shall be valid only if they are initialed by the person or persons signing the bid.

Please note: A single bidder may not bid on the same tender via more than one company under his or her ownership. In addition, bidders having close relationships with other bidders (members of the same family, subsidiary, or daughter companies, etc.) may not bid on the same tender. This type of action, or any other action judged by the Purchaser to constitute collusive behavior, will lead to the bidder(s) being automatically eliminated from this tender and disqualified from participating in future IRC tenders. On the other hand, one bidder may submit more than one offer in response to the same tender only if the offers demonstrate clear differences in specifications, quality, lead time, and other characteristic of the goods and services offered.

D. SUBMISSION OF BIDS

14. Submission and Marking of Bids:

15. Submission and Marking of Bids:

Bidder shall submit sealed bids addressed to:

**The Procurement Committee,
International Rescue Committee,**

**15ML house No. 1/3 Daim Hamad shareg area, Gedaref, Sudan
, Gedaref, Gedaref State.**

All bids shall be submitted before 4:00pm on the 30th of October 2023 (Central African Standard Time). All bids are to be put into the box by the Provider provided for the purpose.

NOTE: Bids submitted after the deadline will not be accepted.

Bidders shall sign the bid register form at the reception of the IRC office indicating their company name, telephone number, and date of submission. This is only if the bidder fails to submit through e-mail.

The PURCHASER may, at its discretion, extend the deadline for the submission of bids, in which case all rights and obligations of the PURCHASER and Bidders, as documented in the RFP, will be applicable to the new deadline. Please make sure the platform you use for uploading your proposal does not expire.

Format

The Bidder's proposal shall include a technical proposal and a financial proposal, in separate sealed envelopes/Folders. *Indicate the reference number and description on the folder as indicated on page 1.* The eligibility documents requested in the "Bid opening and evaluation" section below should be submitted together with the technical proposal envelop/Folder should be properly labeled as "Technical Proposal". The financial proposals should also be properly labeled as "Financial Proposal".

16. Modification and Withdrawal of Bids

The Bidder may modify or withdraw its Bid after submission, provided that written notice of the modification, including substitution or withdrawal of the Bids, is received by the Purchaser prior to the deadline prescribed for submission of Bids.

The Bidder's modification or withdrawal notice shall be prepared, sealed, marked, and dispatched. No Bid may be modified after the deadline for submission of bids.

E. BID OPENING AND EVALUATION

17. Preliminary Examination

The Purchaser will examine the bids to determine whether they are complete, whether any computational errors have been made, whether required sureties have been furnished, whether the documents have been properly signed and whether bids are generally in order.

18. Evaluation and Comparison of Bids

Bids determined to be substantially responsive as per section 7 above will be considered evaluated by the IRC Procurement Committee, with the below scoring criteria.

EVALUATION CRITERIA	Description	Weight (%)
Eligibility	Refers to Bidder's ability to demonstrate that they have valid business registration, tax certificate, and all registration documents as required by the laws of Sudan .. Eligibility criteria will be scored YES / NO. Yes, will proceed to full technical evaluation and NO will be excluded from Technical and Financial evaluation.	Preliminary to pass to the next stage
Key Staff Capacity	Contractor's Site Supervisor should be a qualified civil Engineer (bachelor's degree) or equivalent with at least five years project management experience. (Attach CV). Refers to the technical experience of the responsible civil engineers and those individuals who are assigned to this project. The presented personnel shall work with the IRC to supervise the construction and must be present to deliver the project.	10%
Contractor's Past experience	Refers to bidders' ability to demonstrate relevant experience and technical knowledge of the services required, experience working with IRC, other INGOs, UN Agencies, and Government Institutions. At least five projects of similar value and complexity over the past three years. Provide at least five Certificates of Completion or recommendations from past INGO, Government or UN clients for construction works. Provide IRC Certificate of Completion if available. Attaching contracts or photos alone will not earn any score	20%
Program of Work	Refers to Bidder providing most advantageous Work schedule in terms of weeks (7days/Week). Please specify in weeks for each structure in case you are bidding for more than one structure	20%
Construction machinery	Refers to Bidder's ability to demonstrate that they have the following construction machinery/equipment: <ul style="list-style-type: none"> • Dump /Tipper truck, • Water Tanker • Utility Heavy Truck (at least 10tons) • Light Vehicle (at least 2 tons) Concrete mixer, • Compactor. • Poker Vibrator Provide evidence of ownership (Receipt/Vehicle Registration Book) of all the above machines. Making a list of the items only will not earn you any score. Provide lease agreement where applicable.	10%
Ability to complete most of the work. on its own finances	100% of work completed by contractor's own resources. Please make this in form of a letter, stamp and sign it and provide 4 months Bank statement.	5%
Payment Terms	Refers to bidder providing the most favorable terms of payment. The Purchaser payment terms are to pay within 30 calendar days of acceptance of services and receipt of invoice.	5%
Financial Proposal	Most competitive offer as per price Schedule/Bill of Quantities	30%
TOTAL% SCORE		100%

19. Contacting the Purchaser

Subject to Clause 5, no Bidder shall contact the Purchaser on any matter relating to its bid, from the time of the bid opening to the time the Contract is awarded, or the selected qualified Contractor is announced.

20. Notification of Award

Prior to the expiration of the period of bid validity, the Purchaser shall notify the successful bidder in writing or where necessary by telephone that his or her bid has been accepted and, selected for the construction works. At this stage IRC may also choose to negotiate with the selected bidder to finalize the offer.

F. CONTRACTING

21. Contract award and notification

The Purchaser shall award the Contract to the notified successful Bidder(s) whose bid has been determined to be substantially responsive and has been determined to be the best evaluated bid considering price and performance factors, provided further that the Bidder is determined to be qualified to enter into a contract and perform its obligations satisfactorily.

22. Warranty

The Contractor shall warrant that the goods to be supplied are new, unused, of the most recent or current models (products) and meet the Purchaser's specifications.

The warranty shall remain valid for a period of time as may be specified by the in the Bid and this warranty period shall be considered as one of the bids advantages, and shall in no case be less than that which is provided for by Sudan Law if any.

23. Inspection

The Purchaser shall have the right to inspect the goods to confirm their conformity to the specification. The inspection will be conducted by assigned staff of the Purchaser or a reputable relevant consultant selected by the Purchaser.

In the future business relation, should any inspected goods fail to conform to the specification, the Purchaser may reject them, and the Bidder shall replace the rejected goods without extension of time except at the Purchaser's sole discretion.

24. Price Schedules and Location

The construction works will take place in the respective locations indicated in the table Under section 2. **The Purpose of this Request for Proposal (RFP)**

25. Service or consultant agreements

For service or consultant agreements time and material awards are not authorized unless it is the only suitable award, and a ceiling is established.

26. Disclaimer

The Purchaser reserves the right to alter the dates of the timetable.

The Purchaser does not bind itself to accept the lowest or any proposal.

G. ETHICAL OPERATING STANDARDS

1. Compliance to the IRC Way

The IRC Way: Standards for Professional Conduct ("The IRC Way"), the IRC's code of conduct, which can be found at: <https://www.rescue.org/page/our-code-conduct> and IRC's combating Trafficking in Persons Policy, which can be found at: <https://rescue.app.box.com/s/h6dv915b72o1mapxg3vczbqxjtboyel>. The IRC Way provides three (3) core values - Integrity, Service, and Accountability – and twenty-two (22) specific undertakings.

The IRC Way provides, inter alia, that IRC does "not engage in theft, corrupt practices, nepotism, bribery, or trade in illicit substances." IRC's procurement systems and policies are designed to maximize transparency and minimize the risk of corruption in IRC's operations.

IRC requests that a contractor

- (i) informs IRC upon becoming aware that the integrity of IRC's business has been compromised during the RFP process, and
- (ii) Reports such events through IRC's confidential hotline, Ethics point, which can be accessed at www.ethicspoint.com or via toll-free (866) 654-6461 in the U.S., or collect (503) 352-8177 outside the U.S.

2. Bidder Non-Collusion Statement

IRC prohibits collusion and will disqualify all bids where collusion is detected. Collusion happens when related parties submit separate bids for the same tender. Collusion includes situations where:

- a) Members of the same family submit separate bids for the same tender.
- b) Separate companies owned by the same person submit separate bids for the same tender.
- c) Employees of a bidding company submitting separate bids through companies they own for the same tender.
- d) Partners in a bidder submitting separate bids under their own names/ companies they own for the same tender.

It is collusion for a person to be involved in more than companies/ businesses submitting a bid to the same tender. Collusion will lead to IRC disqualifying the involved Individuals or companies from that tender as well as disqualify them from submitting bids for future tenders. In addition, IRC may share information relating to this collusion with other international aid organizations operating in the region leading to loss of business opportunities for the colluders.

H. Annexes

- Annex A: Bidders must submit their financial offers in accordance with the BOQs provided under ANNEX A of this RFP document. Bidders who wish to use their own format must ensure that they include the minimum information given in Annex A.
- Annex B Technical specifications
- Annex C Technical Drawings
- Annex D Vendor Information form
- Annex E IRC Conflict of Interest and Supplier Code of Conduct form
- Annex F Intent to Bid Form
- Annex G Proposed work and activity schedule
- Annex H Certificate of Pre-Tender Site Inspection

Annex: A PRICE SCHEDULE - (CONSTRUCTION OF TWO STAND PIT LATRINE AND PATHING SHELTERS)

LOT: A

CONSTRUCTION OF PIT LATRINE - TWO STANCE [ZINC SHEET CLADDING] TUNAYDBAH CAMP					
ITEM	DESCRIPTION	UNIT	Quantities	Unit Cost SDG	Total Amount

1	<u>BILL No 1: SUBSTRUCTURE (ALL PROVISIONAL)</u>		-		
1-1	<u>EXCAVATIONS, EARTHWORKS AND DEMOLITIONS</u>		-		
	Excavations				
	Excavate pit commencing from ground level average depth 3.5m, Dia 3.16m and cart away from site.	CM	27.44		
	Excavate holes commencing from ground level average depth 450mm diameter 100mm; 14 No holes excavated.	NO	14.00		
	Return, fill-in and rum selected excavated material around external bottom level to the superstructure cladding.	CM	1.22		
1-2	Filling				
1-2-1	Approved Murrum material				
	REPLACE THE BLACK COTTON SOIL IN THE BOTTOM OF THE PIT WITH DIFFERENT SOIL MATERIAL WITH DEPTH 0.5m	CM	3.92		
	REPLACE THE SOIL BETWEEN THE EXTERNAL LINING WALL AND THE BLACK COTTON SOIL WITH DIFFERENT SOIL, WITH WIDTH 500MM DEPTH 3000MM COMPACTED IN LAYERS OF 150MM	CM	12.53		
	To make up levels depositing and compacting in layers maximum 75mm thick in making up levels in sections not covered by slab.	CM	0.40		
1-2-2	Landscaping				
	General site landscaping, clearance and making site environmentally acceptable and safe for users	LS	1.00		
1-3	<u>CONCRETE WORK</u>		-		
1-3-1	In situ Concrete and Reinforcement				
	Concrete				
	<u>Mix and place Normal:class 10 vibrated (1:3:6) in</u>		-		
	Pit foundation slab 100mm thick including the the cover of the desludging opening, R=1.58m	CM	0.78		

1-3-2	Reinforcement				
	Supply nad fix bars high yield steel & mild steel; cold worked B:S 4461 including bends, hooks, tying wire, spacer blocks and spacers in position				
	10mm diameter X- bars in pit latrine slab (0.62Kg/m)	KG	34.32		
	10mm diameter Y- bars in pit latrine slab (0.62Kg/m)	KG	34.32		
1-3-3	<u>Plastic sheet sealing:</u>		-		
	supply and lay available plastic sheet under the foundation slab and over 50mm leveling sand layer	SM	7.35		
	Total Carried to Collection Page 01				
1-4	<u>Mix and place Normal:class 20 vibrated (1:2:4) in</u>		-		
	-		-		
	<u>Pit latrine slab 100mm thickness (casting over plastic sheet and covered by soucks to ensure good curing) including ramp. As per the engineer guieds</u>	CM	0.38		
1-4-1	Reinforcement				
	Supply nad fix bars high yield steel & mild steel; cold worked B:S 4461 including bends, hooks, tying wire, spacer blocks and spacers in position and formwork.				
	10mm diameter X- bars in pit latrine slab (0.62Kg/m)	KG	17.33		
	10mm diameter Y- bars in pit latrine slab (0.62Kg/m)	KG	17.33		
	18mm diameter Y- bars in pit latrine slab (0.62Kg/m) for handles of the PWD	KG	32.98		
1-5	<u>Ventilation Pipe</u>		-		
	Supply and install PVC ventilation pipe 4 inch diameter, and 3mm thickness, and cover the top of the pipe by plastic wire mesh, and use rainproof putty around the pipe on the roof.	LM	3.00		
1-6	<u>PIT WALL LINING</u>		-		

	Burnt clay brick walling in cement and sand mortar (1:3) with hoop iron 500 guage at alternatives courses (0.5m above GL 3m under GL) thickness 330mm (1.5 brick) including the desludging opening,	SM	23.74		
1-7	<u>INTERNAL FINISHES</u>		-		
	<u>Floor</u>		-		
	Cement sand screed 1:3				
	70mm thick, Screed on top of compacted murrum filling to pit latrine floor on sections/surfaces not covered by slab	CM	0.09		
	Total Carried to Collection Page 02				
	<u>Collection</u>		-		
	Brought forward from page 01				
	Brought forward from page 02				
	Total for BILL NO. 1 Carried to Summary				
	<u>BILL No 2: SUPERSTRUCTURE WALLING</u>		-		
1-8	<u>Walling cladding</u>		-		
	Supply approved R.steel box 3x6 2.5mm thickness posts painted to resistant the corrosion and weather, height n.e. 2720mm, thickness, not below 1mm, installed in holes, backfilled with concrete 1:2:4 mix. And fixed by steel box rows 2.5x5 to hold cladding into place	No.	14.00		
	Supply and fix, Zinc sheet 0.35 (sides) to cover/clad framed steel structure; covering to be firmly fastened against the structure frame using additional R.steel box 2.5 x5 (thickness n.e. 2.5mm) on the internal surfaces in 3 rows and crossed to hold the zinc sheet cladding in place. welded and nailed. 1.5 steel plate 1mm thickness for external serface to hold zinc sheet. total price including steel box rows.	SM	32.20		
1-9	<u>ROOF COVER</u>		-		
	-		-		

	Supply approved R.steel box 2.5x5 2.5mm thickness posts painted to resistant the termites and weather, length n.e. 3300mm, thickness not below 1.5mm, as purlin members fixed in place on rafters welded to support roof cladding	No.	6.00		
	-		-		
	Supply and fix, Zinc sheet 0.35 (roof) to cover/clad framed steel structure; covering to be firmly fastened against the structure frame using additional steel plate 1.5 (thickness n.e. 3.0mm) on the external surfaces in 3 rows using nails to hold the zinc sheet cladding in place.	SM	11.56		
	-		-		
	Total for BILL NO. 2 Carried to Summary				
	<u>BILL No 3: DOORS AND WINDOWS</u>		-		
1-10	<u>DOORS</u>		-		
1-10-1	<u>External</u>		-		
	Supply and fix 50mm thick door shutter, size 2000mm x 800mm to fit door space; framed with 3x6 2.5mm steel box posts locally and covered with zinc sheet 0.35 mm thickness to size and fixed with capped wire nails; and with 2 hooks at top door frame internally. total price including ironmongery (all accessories 3matching, 2bolt and locks, ...)	No.	2.00		
	Total for BILL NO. 3 Carried to Summary				
	<u>BILL No 4: PIT LATRINE ACCESSORIES</u>		-		
	-		-		
1-11	<u>Squat hole cover</u>		-		
	Supply, fix and install wooded pit latrine squat hole cover made with a handle to lift and place to cover squat hole (see specifications). Fabricated to fit squat hole cover without allowing any spaces in the sides.	LS	2.00		
1-12	<u>Painting:</u>		-		
	Painting the superstructure with anti-crrosion painting (zaligon)	SM	43.76		
1-13	<u>Zinc sheet edges protection:</u>		-		

	supply plastic sheet thickness 3mm to protect zinc sheet edges to get rust	Item	1.00		
	Total for BILL NO. 4 Carried to Summary				
	<u>SUMMARY</u>		-		
	-		-		
1	CARRIED FROM BILL No 1: SUBSTRUCTURE AND DEMOLITIONS				
2	CARRIED FROM BILL No 2: SUPERSTRUCTURE WALLING AND CONCRETE WORKS				
3	CARRIED FROM BILL No 3: DOORS AND WINDOWS				
4	CARRIED FROM BILL No 4: PIT LATRINE ACCESSORIES				
	GRAND TOTAL COST				

LOT B

CONSTRUCTION OF BATHING SHELTER [ZINC SHEET CLADDING] TUNATDBAH CAMP					
ITEM	DESCRIPTION	UNIT	Quantities	Unit Cost SDG	Total Amount
	<u>BILL No 1: SUBSTRUCTURE (ALL PROVISIONAL)</u>				
	<u>EXCAVATIONS, EARTHWORKS AND DEMOLITIONS</u>				
	Excavations				
	Excavate holes commencing from ground level average depth 500mm diameter 300mm; 7 No holes excavated.	NO	7.00		

A	Excavate foundation commencing from ground level average depth 170mm and cart away from site ave distance not more than 15metres.	CM	0.22		
	Excavate foundation commencing from from ground level average depth 75mm and cart away from site ave. distance not more than 15metres.	CM	0.04		
	Excavate pit for soak pit commencing from ground level average depth 1000mm, dimation 1000mm by 3000m and cart away from site ave distance not more than 15metres.	CM	3.38		
	Excavate trench for waste water commencing from from ground level average depth 225mm, width 200mm and cart away from site ave distance not more than 15metres.	CM	0.15		
	Remove and cart away from site surplus excavated materials on site n.e. 100m as directed	LS	1.00		
	<p>Filling Approved Hardcore material Entrance to the shelter, to make up levels depositing and compacting in layers maximum 75mm thick in making up levels.</p>	CM	0.04		
Total Carried to Collection Page 01					
A	Inside shelter at the bathing area to make up levels depositing and compacting in layers maximum 120mm thick in making up levels.	CM	0.15		
	In the soak pit to make up levels depositing by Stones in layers maximum 120mm thick in making up levels, average depth 2500mm	CM	2.25		
	In the soak pit to make up levels depositing by Gravel in layers maximum 75mm thick in making up levels, average depth 400mm	CM	0.90		
	<p>Approved Murrum material Suuply Murrum materials in the last Layer of the Pit with depth 100mm</p>	CM	0.23		
	<p>Landscaping Genaral site landscaping, clearance and making site environmentally acceptable and safe for users</p>	LS	1.00		

A	<p><u>CONCRETE WORK</u> Insitu Concrete and Reinforcement Concrete <u>Normal: class 15 vibrated (1:3:6) in</u></p>				
	In Bathing area and waste water trench (section inside shelter) 60mm thick	CM	0.09		
	fill-in the hole to support the steel box posts	CM	0.25		
	Total Carried to Collection Page 02				
	<p><u>Collection</u> Brought forward from page 01 Brought forward from page 02</p>				
	Total for BILL NO. 1 Carried to Summary				
A	<p><u>BILL No 2: SUPERSTRUCTURE WALLING</u> <u>Walling cladding</u></p> <p>Supply approved R.steel box 3x6 1mm thickness posts painted to resistant the termites and weather, height n.e. 2720mm, thickness not below 1mm, installed in holes, back filled with concrete 1:2:4 mix.</p>	No.	7.00		
	B	<p>Supply and fix, Zinc sheet 0.35 (sides) to cover/clad framed steel structure; covering to be firmly fastened against the structure frame using additional R.steel box 2.5 x5 (thickness n.e. 1.0mm) on the internal surfaces in 3 rows to hold the zinc sheet cladding in place. welded and nailed. 1.5 steel plate 1mm thickness for external serface to hold zinc sheet. total price including steel box rows.</p>	SM	14.16	
	<p><u>ROOF COVER</u></p>				

C	Supply approved R.steel box 2.5x5 1mm thickness posts painted to resistant the termites and weather, length n.e. 3300mm, thickness not below 1mm, as purlin members fixed in place on rafters welded to support roof cladding	No.	4.00		
	Supply and fix, Zinc sheet 0.35 (roof) to cover/clad framed steel structure; covering to be firmly fastened against the structure frame using additional steel plate 1.5 (thickness n.e. 1.0mm) on the external surfaces in 3 rows using nails to hold the zinc sheet cladding in place.	SM	3.60		
	Supply and fix, Iron shelf 225x300s25mm, installed adeqautely supportedto fit firmly on steel box and zinc sheet cladding.	LS	1.00		
Total for BILL NO. 2 Carried to Summary					
<u>BILL No 3: DOORS AND WINDOWS</u>					
<u>DOORS</u>					
<u>External</u>					
A	Supply and fix 50mm thick door shutter, size 2000mm x 800mm to fit door space; framed with 3x6 1mm steel box posts locally and covered with zinc sheet 0.35 mm thickness to size and fixed with capped wire nails; and with 2 hooks at top door frame internally. total price including iron Mongery (all accessories)	No.	1.00		
<u>Iron Mongery</u>					
B	Supply and fix with matching including nails 100mm pairs steel hinges	NO	3.00		
G	100mm long steel Pad bolt, complete with accessories	No	1.00		
H	100mm long steel latch bolt complete with accessories	No	1.00		
<u>Drinage Pipe</u>					
	Suppy and Install Drinage Pipe PVC 4 inchs and connected tfrom the trench to the soak Pit with the required fittings.	LM	1.50		
<u>Painting:</u>					

1	Painting the superstructure with anti-croosion painting (zaligon)	SM	17.76		
	Zinc sheet edges protection: supply plastic sheet thickness 3mm to protect zinc sheet edges to get rust	Item	1.00		
	CARRIED FROM BILL No 1: SUBSTRUCTURE AND DEMOLITIONS				
2	CARRIED FROM BILL No 2: SUPERSTRUCTURE WALLING AND CONCRETE WORKS				
3	CARRIED FROM BILL No 3: DOORS AND WINDOWS				
	TOTAL ESTIMATED COST				

ANNEX B: TECHNICAL SPECIFICATIONS –

Sanitation Facilities

Iron Works:

All Iron poles be new, well-seasoned and free from loose knots, shakes, cracks, warping, and other defects. it shall be properly stacked and protected from injury from any sources.

Any Iron sheets poles which bad warped or cracked, shall be rejected.

Iron shelf in the female facilities:

Iron plate dimensions (225x300x25mm) should be properly fixed to the (Iron Sheet) and welded to the Iron tube.

Squat Whole cover for pit latrine:

Made from piece of timber with a handle to lift and place to cover squat hole the dimensions same as the latrine whole plus 5mm in each side to fit to latrine hole without allowing any spaces in the sides.

Doors:

The thick door shutter should be 50mm and dimensions is size 2000mm x 800mm to fit door space; steel box posts and covered with **Zinc sheet** 0.35 to size and fixed

with capped wire nails. With three hinges (in the top, middle and bottom to make the door easily open and close) and two latches from inside and outside the door fixed with capped wire nails.

Iron sheet cladding:

Made from iron sheets unreflecting and protect the privacy with height not less than 2m.

Internal wall/screen surface PVC cover:

Dark colored PVC Tarpaulin sheeting to internal screening surface of the sanitation facilities fixed and fastened with appropriate wire rope string.

Brick wall lining to pit latrines:

Use solid burnt bricks with compressive strength approved by Local Authority guidelines or not less than 7.5N/mm² and of size 200x100x50mm. The **compressive strength** of any individual **brick** shall not fall below the **minimum average compressive strength** by more than 20%.

Mortar mix:

Boding of mortar for the brick wall lining shall be of mix 1:3 cement/sand or shall be advised by the site engineer depending on the quality of sand available.

Concrete mix:

Composition of concrete shall be a homogeneous mixture of coarse aggregate, fine aggregate, water and Ordinary Portland cement, all as specified in the relevant Clauses of this Specification, together with any such admixture as the Engineer may specify or approve.

Classes of Concrete Table: CLASS	Characteristic Compressive Strength (N/mm ²)	Maximum Aggregate size (mm)	Maximum free Water/ Cement Ratio	Minimum Cement Content (Kg/m ³)	Maximum cement Content (Kg/m ³)
C20/20	20	20	0.55	390	400
C10/40	10	40	0.55	150	540

Compressive Strength (N/mm²)/Aggregate size (mm)

Mix Design Table: Class	Portland cement, kg	Fine Aggregates, m ³	Coarse Aggregates, m ³	Nominal Mix proportions
20	50	0.07	0.14	1:2:4
10	50	0.1	0.2	1:3:6

Steel:

Bars shall be high yield steel & mild steel; cold worked according BS 4461 and BS 4449 including bends, hooks, tying wire, spacer blocks and spacers steel bar Dia 10 mm

All reinforcement should be free from contamination and grease. light corrosion should be brushed to remove the rust.

Steel Box:

All steel box thickness not less than 1.5mm

Corrugated Zinc sheet:

Corrugated zinc sheet must be high quality and thickness not less than 0.35.

Landscaping and site clearance:

Areas should be cleared of all debris and the contractor should avoid practice that affects the environment negatively. Slab level to all pit latrine facilities shall be 250mm above ground level.

Annex C: Technical Drawings

1- Bathing Shelter Plan, Sect, Drainage, Door

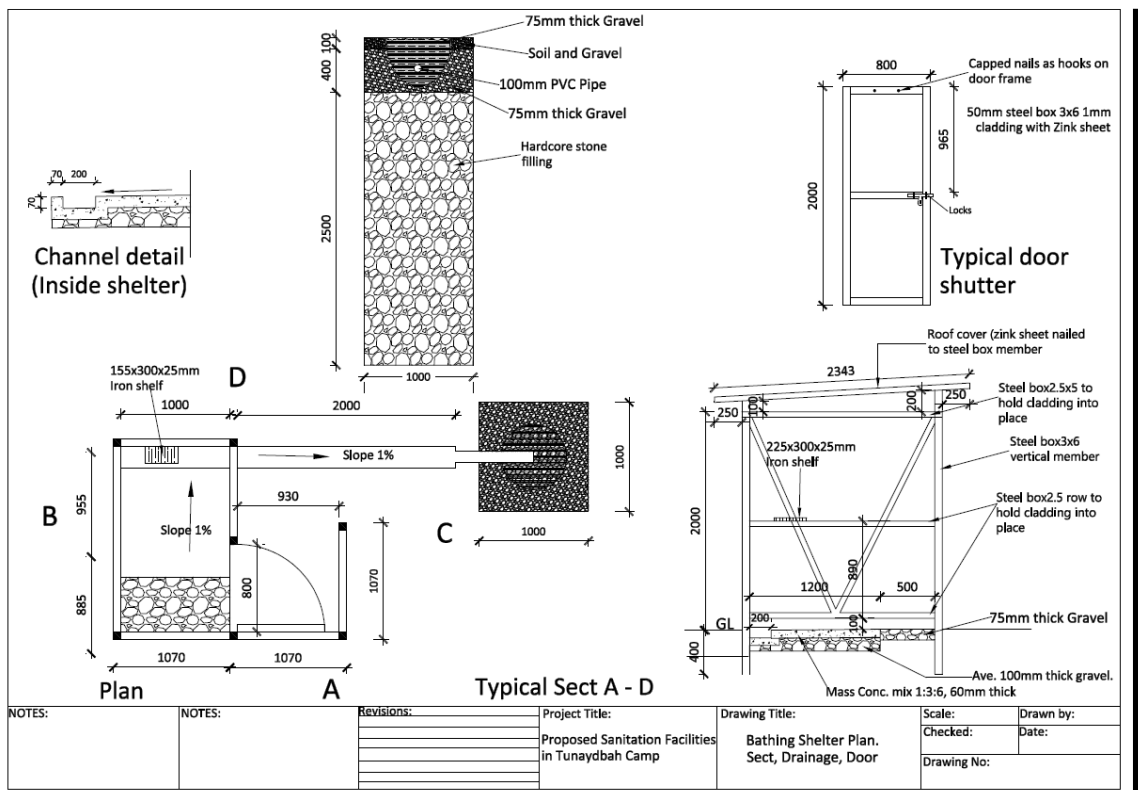

2- Bathing Shelter Plan, Sect, Drainage, Door

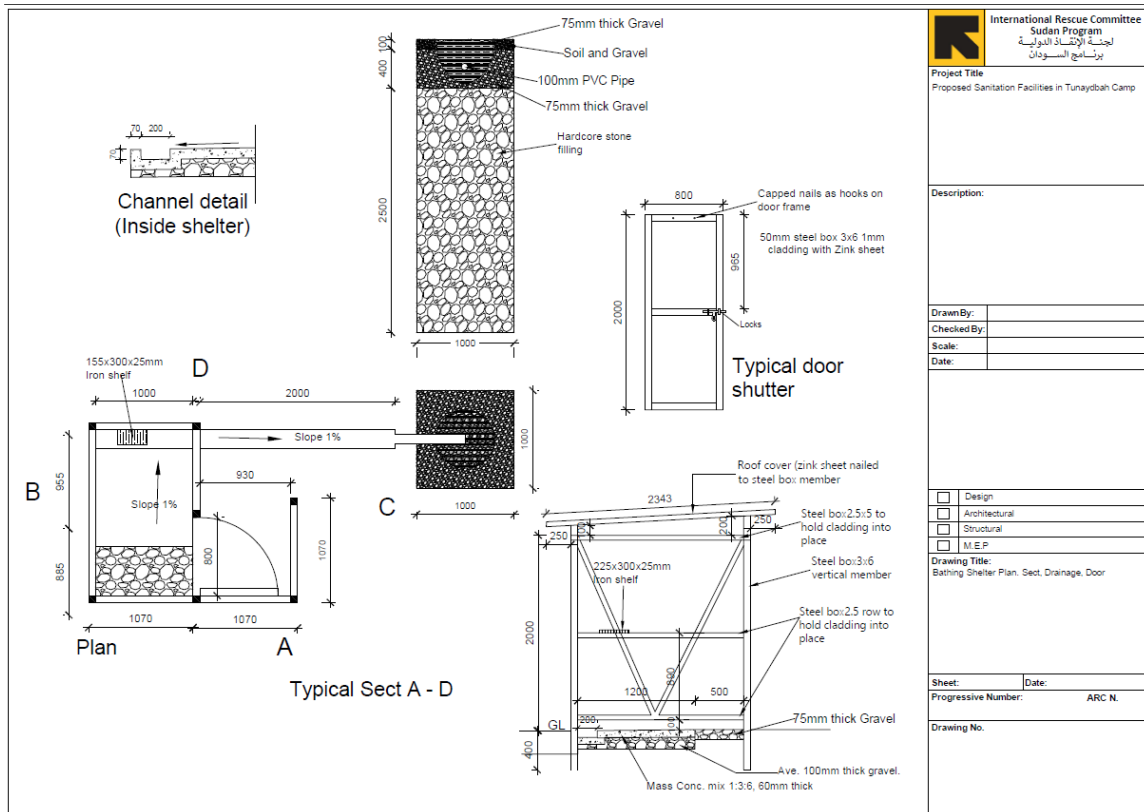

Project Title Proposed Sanitation Facilities in Tunaydah Camp	
Description:	
Drawn By:	
Checked By:	
Scale:	
Date:	
<input type="checkbox"/> Design <input type="checkbox"/> Architectural <input type="checkbox"/> Structural <input type="checkbox"/> M.E.P.	
Drawing Title: Bathing Shelter Plan, Sect. Drainage, Door	
Sheet:	Date:
Progressive Number:	ARC N.
Drawing No.	

3- Single Stance Bathing Space Elevations.

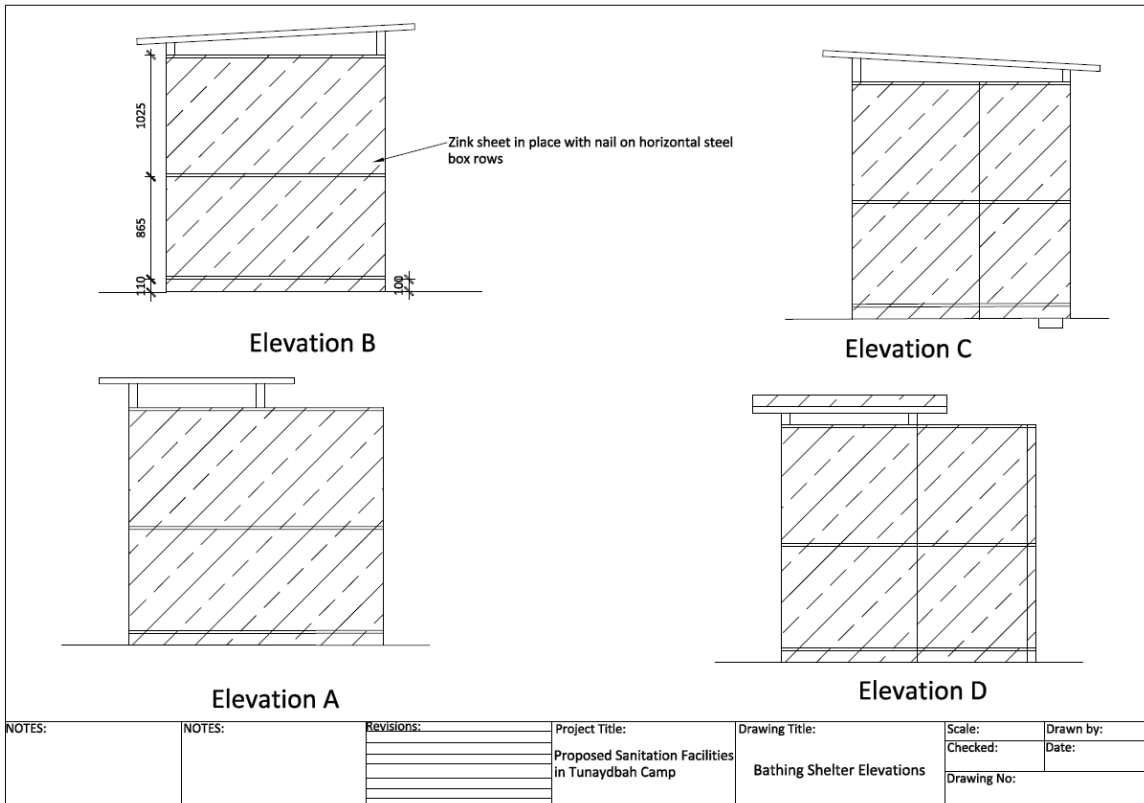

NOTES:	NOTES:	Revisions:	Project Title: Proposed Sanitation Facilities in Tunaydah Camp	Drawing Title: Bathing Shelter Elevations	Scale:	Drawn by:
					Checked:	Date:
					Drawing No.:	

4- Single Stance Bathing Space Elevations

Zink sheet in place with nail on horizontal steel box rows

Elevation B

Elevation C

Elevation A

Elevation D

International Rescue Committee Sudan Program لجنة الإنقاذ الدولية برنامج السودان	
Project Title Proposed Sanitation Facilities in Tunaybah Camp	
Description:	
Drawn By:	
Checked By:	
Scale:	
Date:	
<input type="checkbox"/> Design <input type="checkbox"/> Architectural <input type="checkbox"/> Structural <input type="checkbox"/> M.E.P.	
Drawing Title: Bathing Shelter Elevations	
Sheet:	Date:
Progressive Number: ARC N.	
Drawing No.	

The drawing consists of three cross-sectional views of a latrine structure. The top view shows a structure with a flat roof and a concrete ramp on the right side. The middle view shows a similar structure with a 'Desludging Opening' at the base. The bottom view shows a structure with a concrete ramp on the left side. Labels include: Rainproof putty, Iron sheet (Zink) cladding tied in place with nails on horizontal iron tubes, steel box rows 2.5x5 to hold cladding into place, Desludging Opening, and Concrete Rambu. Ground level is marked as 'GL'.

International Rescue Committee Sudan Program لجنة الإغاثة الدولية برنامج السودان	
Project Title Proposed Sanitation Facilities in Tunaybah Camp	
Description:	
Drawn By:	
Checked By:	
Scale:	
Date:	
<input type="checkbox"/> Design <input type="checkbox"/> Architectural <input type="checkbox"/> Structural <input type="checkbox"/> M.E.P.	
Drawing Title: Pit Latrine Elevations	
Sheet:	Date:
Progressive Number:	ARC N.
Drawing No.	

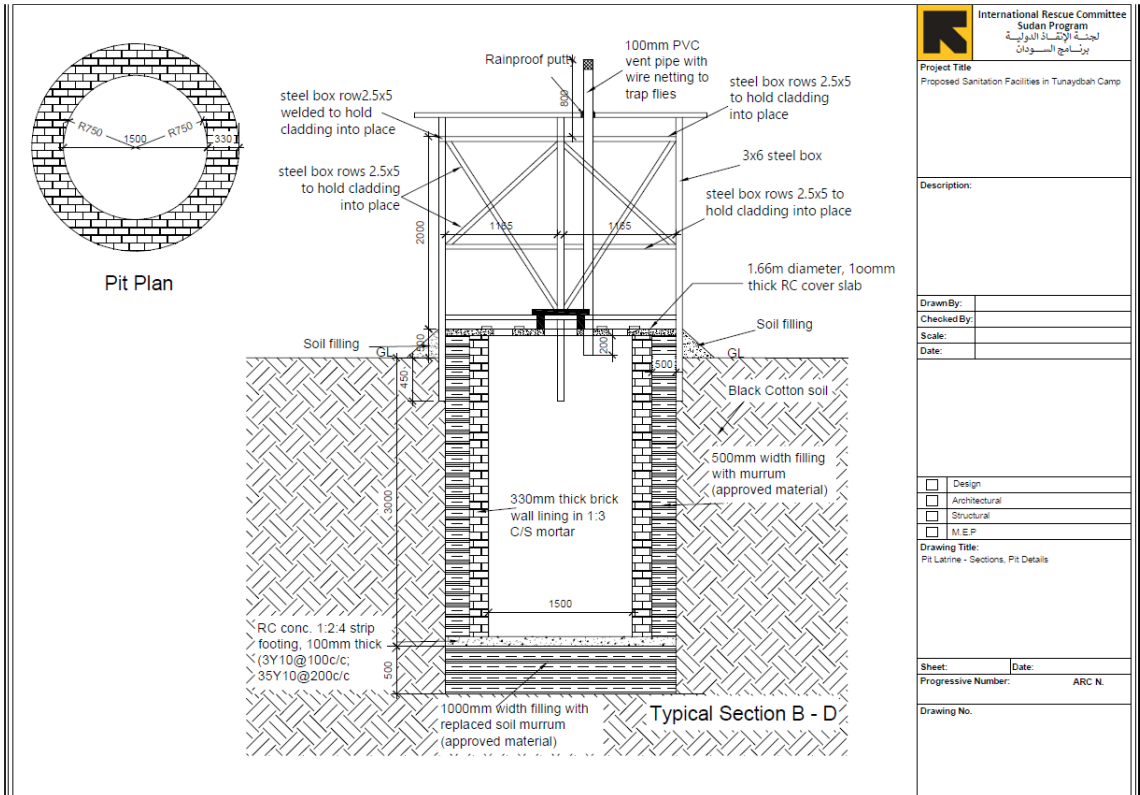

International Rescue Committee Sudan Program لجنة الإنقاذ الدولية برنامج السودان	
Project Title Proposed Sanitation Facilities in Tunaybah Camp	
Description:	
Drawn By:	
Checked By:	
Scale:	
Date:	
<input type="checkbox"/> Design <input type="checkbox"/> Architectural <input type="checkbox"/> Structural <input type="checkbox"/> M.E.P.	
Drawing Title: Pit Latrine - Sections, Pit Details	
Sheet:	Date:
Progressive Number:	ARC N.
Drawing No.	

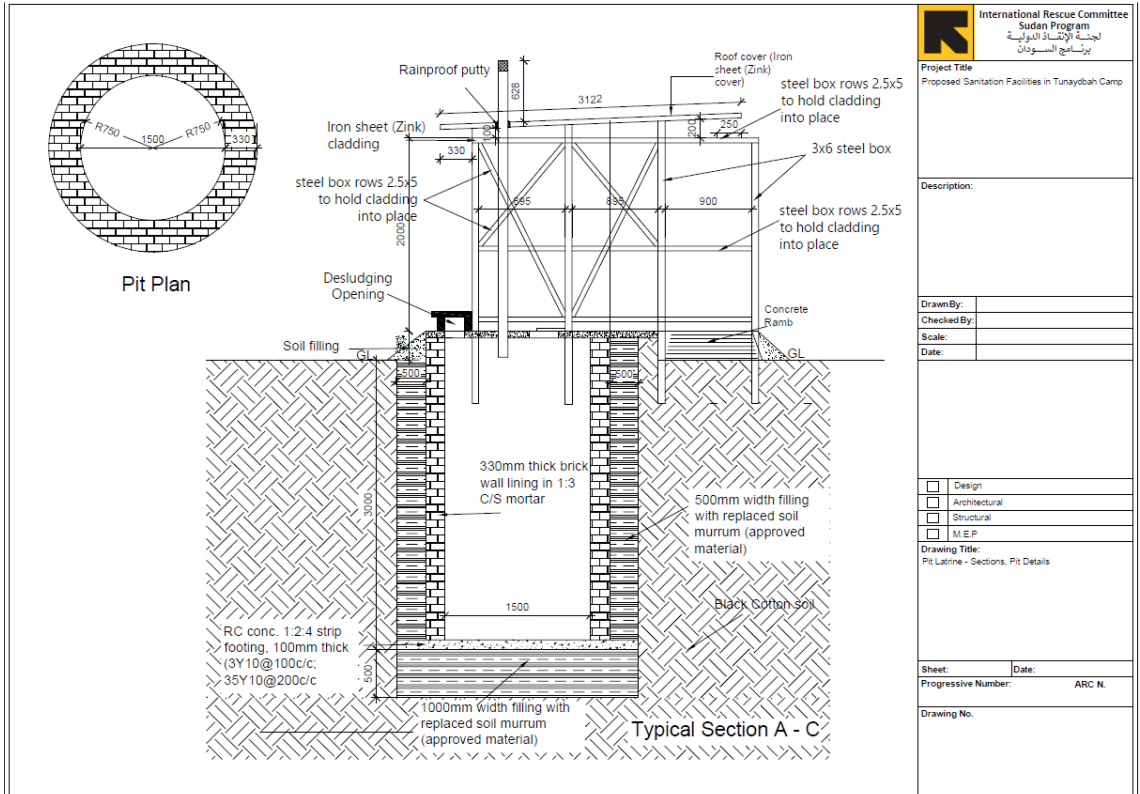

International Rescue Committee Sudan Program لجنة الإنقاذ الدولية برنامج السودان	
Project Title Proposed Sanitation Facilities in Tunaybah Camp	
Description:	
Drawn By:	
Checked By:	
Scale:	
Date:	
<input type="checkbox"/> Design <input type="checkbox"/> Architectural <input type="checkbox"/> Structural <input type="checkbox"/> M.E.P.	
Drawing Title: Pit Latrine - Sections, Pit Details	
Sheet:	Date:
Progressive Number:	ARC N.
Drawing No.	

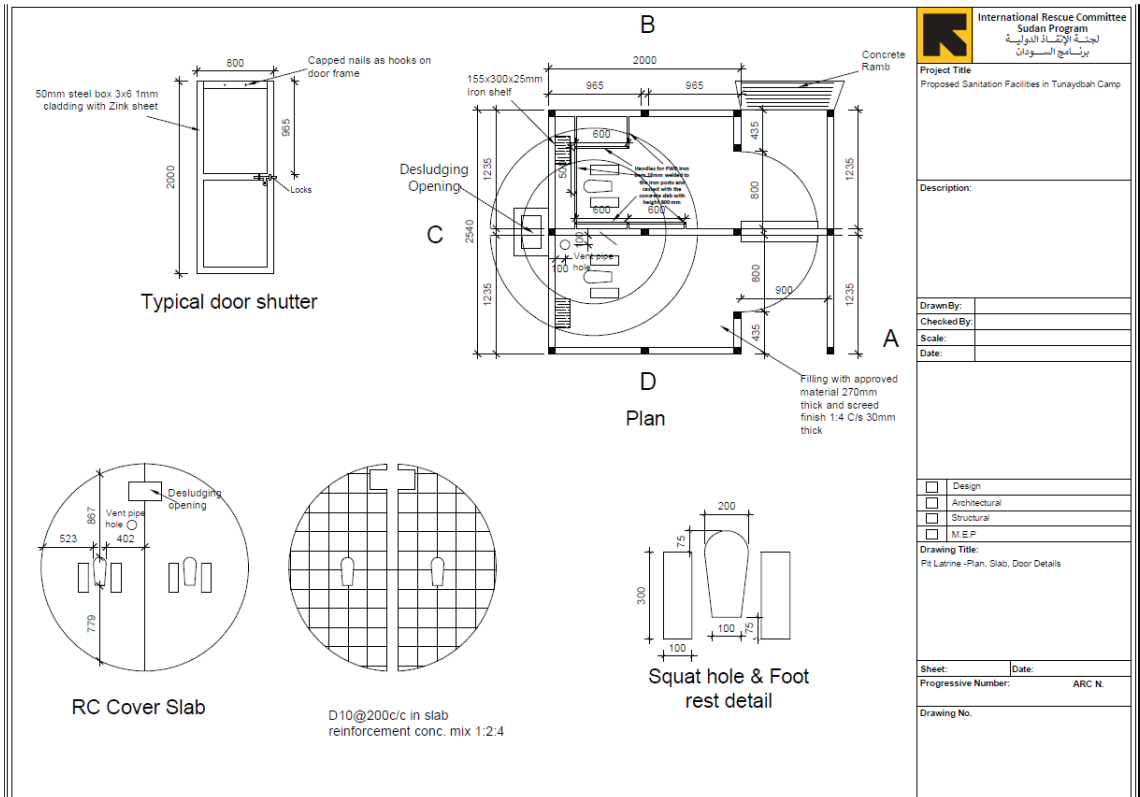

 International Rescue Committee Sudan Program لجنة الإنقاذ الدولية برنامج السودان	
Project Title Proposed Sanitation Facilities in Tunaybah Camp	
Description:	
Drawn By:	
Checked By:	
Scale:	
Date:	
<input type="checkbox"/> Design <input type="checkbox"/> Architectural <input type="checkbox"/> Structural <input type="checkbox"/> M.E.P.	
Drawing Title: Pit Latrine - Plan, Slab, Door Details	
Sheet:	Date:
Progressive Number:	ARC N.
Drawing No.	

Annex D: Vendor Information form



**INTERNATIONAL RESCUE COMMITTEE
Vendor Information Form**

The information provided will be used to evaluate the Company before contracting with the IRC.

Please complete all fields.

Fields marked (*) are mandatory.

Vendor Information

*Company\Organization Name		
*For individual vendors, provide legal first and last name		
*Any other names company is operating under (Acronyms, Abbreviations, Aliases) if any		
*Previous names of the company		
*Address		
*Website		
*Phone/Fax Numbers	Phone:	Fax:
*Primary Contact	First Name:	Last Name:
	Phone Number:	Email Address:
*Number of Staff		
Number of Locations		
Avg. \$ Value of Stock on Hand		
*Name(s) of Company Owner(s) or Board of Directors or CEO		
*Parent companies, if any		

*Subsidiary or affiliate companies, if any	
--	--

Financial Information

*Bank Name and Address	
*Name under which company is registered at bank	<u>This field is mandatory if Wire Transfer is the selected payment method</u>
*Specify Standard Payment Terms (Net, 15, 30 days etc.)	
*Payment Method (select all that applies)	Payment By: <u>Check</u> Yes No <u>Wire Transfer</u> Yes No <u>Cash</u> Yes No
*Name under which company is registered at bank	
*Bank account number	<u>This field is to be completed upon notification of awarding of order\contract</u>
Routing Number	<u>This field is to be completed upon notification of awarding of order\contract</u>
Swift code (if applicable)	<u>This field is to be completed upon notification of awarding of order\contract</u>

Product/Service Information

List Range of Products/Services Offered	
Basis For Pricing (Catalog, List, etc.)	

Documentations as applicable:

*Registration	Provided _____ Not provided: _____ Reasons: _____
*Tax ID (W9, Tax exempt certificate. etc.)	Provided _____
US Vendors only *Do you require a Form 1099?	Yes_____ No_____

References (optional)

Client Name:	<u>Contact Name, Phone, Email Address:</u>
--------------	--

Client Name:	<u>Contact Name, Phone, Email Address:</u>
Client Name:	<u>Contact Name, Phone, Email Address:</u>

Vendor Self-Certification of Eligibility

Company certifies that:

1. They are not debarred, suspended, or otherwise precluded from participating in major donor (e.g. European Union, European and United States Government, United Nations) competitive bid opportunities.
2. They are not bankrupt or being wound up, are having their affairs administered by the courts, have entered into arrangements with creditors, have suspended business activities, are the subject of proceedings concerning those matters, or are in any analogous situation arising from a similar procedure provided for in national legislation or regulations.
3. They have not been convicted of an offense concerning their professional conduct.
4. They have not been guilty of grave professional misconduct proven by any means that the contracting authority can justify, or been declared to be in serious breach of contract for failure to comply with their contractual obligations towards any contracts awarded in the normal course of business.
5. They have fulfilled obligations related to the payment of social security contributions or the payment of taxes in accordance with the legal provisions of the country in which they are established or with those of the country where the contract is to be performed.
6. They have not been the subject of a judgment for fraud, corruption, involvement in a criminal organization or any other illegal activity.
7. They maintain high ethical and social operating standards, including:
 - Working conditions and social rights: Avoidance of Child Labor, bondage, or forced labor; assurance of safe and reasonable working conditions; freedom of association; freedom from exploitation, abuse, and discrimination; protection of basic social rights of its employees and the IRC’s beneficiaries.
 - Environmental aspects: Provision of goods and services with the least negative impact on the environment.
 - Humanitarian neutrality: Endeavoring to ensure that activities do not render civilians more vulnerable to attack or bring unintended advantage to any military actors or other combatants.
 - Transport and cargo: Not engaged in the illegal manufacture, supply, or transportation of weapons; not engaged in smuggling of drugs or people.
8. Company warrants that, to the best of its knowledge, no IRC employee, officer, consultant or other party related to IRC has a financial interest in the Company’s business activities, nor is any IRC employee related to principals or owners of the company. Discovery of an undisclosed Conflict of Interest situation will result in immediate revocation of the Company’s Authorized Vendor status and disqualification of Company from participation in future IRC procurement.
9. Vendor hereby confirms that the organization is not conducting business under other names or alias’s that have not been declared to IRC.

10. Vendor hereby confirms it does not engage in theft, corrupt practices, collusion, nepotism, bribery, or trade in illicit substances.

By signing the Vendor Information Form you certify that your Company is eligible to supply goods and services to major donor funded organizations and that all of the above statements are accurate and factual.

Annex E: IRC Conflict of Interest and Vendor Code of Conduct

Supplier hereby agrees that Supplier and Supplier's employees and subcontractors, if any, shall abide by and follow all established written policies of IRC related to work conduct, including, but not limited to, The IRC Way: Standards for Professional Conduct ("The IRC Way"), the IRC's code of conduct, which can be found at: <https://www.rescue.org/page/our-code-conduct> and IRC's Combating Trafficking in Persons Policy, which can be found here: <https://rescue.app.box.com/s/h6dv915b72o1rnapxg3vczbqxjtboyel>.

The IRC Way provides three (3) core values - Integrity, Service, and Accountability – and twenty-two (22) specific undertakings. Supplier acknowledges that all IRC employees and independent contractors are expected to apply these core values and follow these undertakings in carrying out work on behalf of IRC. It is a point of pride for IRC to apply these behavioral standards in IRC's everyday operations.

Integrity - At IRC, we are open, honest and trustworthy in dealing with beneficiaries, partners, co-workers, donors, funders, and the communities we affect.

- We work to build the trust of the communities in which we work and sustain the trust earned by our reputation in serving our beneficiaries.
- We recognize that our talented and dedicated staff are our greatest asset and we conduct ourselves in ways that reflect the highest standards of organizational and individual conduct.
- Throughout our work, IRC respects the dignity, values, history, religion, and culture of those we serve.
- We respect equally the rights of women and men and we do not support practices that undermine the human rights of anyone.
- We refrain from all practices that undermine the integrity of the organization including any form of exploitation, discrimination, harassment, retaliation or abuse of colleagues, beneficiaries, and the communities in which we work.
- We do not engage in theft, corrupt practices, nepotism, bribery, or trade in illicit substances.
- We accept funds and donations only from sources whose aims are consistent with our mission, objectives, and capacity, and which do not undermine our independence and identity.
- We support human rights consistent with the UN Universal Declaration of Human Rights and The Convention on the Rights of the Child.
- We rigorously enforce the UN Secretary General's Bulletin on the Protection from Sexual Exploitation and Abuse of Beneficiaries.
- IRC recognizes its obligation of care for all IRC staff and assumes their loyalty and cooperation.

Service - At IRC, our primary responsibility is to the people we serve.

- As a guiding principle of our work, IRC encourages self-reliance and supports the right of people to fully participate in decisions that affect their lives.
- We create durable solutions and conditions that foster peace, stability and social, economic, and political development in communities where we work.
- We design programs to respond to beneficiaries' needs including emergency relief, rehabilitation, and protection of human rights, post-conflict development, resettlement, and advocacy on their behalf.
- We seek to adopt best practices and evidence-based indicators that demonstrate the quality of our work.
- We endorse the Code of Conduct for the International Red Cross and Red Crescent Movement and NGOs in Disaster Relief.

Accountability - At IRC, we are accountable – individually and collectively – for our behaviors, actions, and results.

- We are accountable and transparent in our dealings with colleagues, beneficiaries, partners, donors, and the communities we affect.
- We strive to comply with the laws of the governing institutions where we work.
- We maintain and disseminate accurate financial information and information on our goals and activities to interested parties.
- We are responsible stewards of funds entrusted to our use.
- We integrate individual accountability of staff through the use of performance evaluations.
- We utilize the resources available to our organization in order to pursue our mission and strategic objectives in cost effective ways.
- We strive to eliminate waste and unnecessary expense, and to direct all possible resources to the people we serve

Conflict of Interest and Legal Compliance

- Supplier hereby warrants that, to the best of its knowledge, no IRC employee, officer, consultant or other party related to IRC has a financial interest in the Supplier's business activities.
- Supplier hereby warrants that, to the best of its knowledge, no IRC employee, officer, consultant or other party related to IRC has a family relationship with the supplier's owners.
- Discovery of an undisclosed conflict of interest will result in immediate termination of any Agreement and disqualification of Supplier from participation in current and future IRC activities.
- Supplier hereby warrants that the organization is not conducting business under other names or alias's that have not been declared to IRC.
- Supplier hereby warrants that it does not engage in theft, corrupt practices, collusion, nepotism, bribery, trade in illicit substances, or terrorism or support of terrorism.
- Supplier hereby warrants that it complies with all applicable laws, statutes and regulations, including, but not limited to, export controls, import controls, customs regulations, trade embargoes and other trade sanctions and laws governing unlawful boycotts and payments to foreign government officials.

Supplier hereby agrees to maintain high ethical and social standards:

- Working conditions and social rights: Avoidance of child labor, bondage, or forced labor; assurance of safe and reasonable working conditions; freedom of association; freedom from exploitation, abuse, and discrimination; protection of basic social rights of its employees and IRC's beneficiaries; prohibition of trafficking in persons.
- Environmental aspects: Provision of goods and services with the least negative impact on the environment.
- Humanitarian neutrality: Endeavoring to ensure that activities do not render civilians more vulnerable to attack or bring unintended advantage to any military actors or other combatants.
- Transport and cargo: Not engaged in the illegal manufacture, supply, or transportation of weapons; not engaged in smuggling of drugs or people.

Disclosures of conflict of interest shall be made in writing to the IRC Supply Chain Coordinator or Deputy Director of Operations in your country. For global procurement, please write to GSCQA. Email: GSCQA@rescue.org

These IRC officials shall then determine whether a conflict exists and is material, and whether the contemplated transaction may be authorized as just, fair, and reasonable. If conflict exists, then the supplier with such a conflict shall be prohibited from participating in the transaction.

If you believe that any IRC employee, volunteer or intern is acting in a manner that is inconsistent with these Standards, please notify a supervisor or the confidential helpline Ethicspoint, irc.ethicspoint.com or call Ethicspoint toll-free (866) 654-6461 in the U.S./call collect (503) 352-8177 outside the U.S. There will be no retaliation against any person who raises concerns that are based on good faith belief of improper conduct. An intentionally false report or a failure to report conduct that is known to violate these standards may result in disciplinary action.

By signing this statement supplier acknowledges any violation of the above IRC policies will result in immediate termination of any agreement in place and disqualification from participation in future IRC activities.

Supplier Name:
Signature:
Title:
Print Name:
Date:

Annex F: Intent to Bid Form



International Rescue Committee, Inc.

Intent to Bid

IRC Reference #: _____

Company Name _____

(Please indicate #1 or #2 below)

1. It is the intent of this company to submit a response to the (Title of RFP) Request for Proposal.

Please provide a name and email address for the person within your company that should receive notices, amendments, etc. that are related to this RFP:

Name _____

Phone _____

Email _____

Signature (If faxed) _____

Title of Person signing _____

Date _____

We realize that this is an intent to bid and in no way obligates this company to participate in this process.

2. This company DOES NOT intend to participate in this RFP.

Name (Signature if faxed) _____

Title of Person signing _____

Date _____

Please fax or email this form at your earliest convenience to the attention of:

Name (YOU) _____

Fax _____

Email _____

Annex G: Proposed work and activity Schedule

SCHEDULE 5: (PROVIDE DESCRIPTION / TITLE OF THE CONSTRUCTION IN THIS SPACE)

No.	Activity Description	Duration (Days)	Week 1					Week 2					Week 3					Week 4					Week 5															
			1	2	3	4	5	6	7	8	9	10	11	12	13	14	15	16	17	18	19	20	21	22	23	24	25	26	27	28	29	30	1	2	3	4	5	

NB: Date of WORKS commencement will be as agreed upon between IRC and the CONTRACTOR.
 SIGNATURE: OFFICIAL SEAL: DATE:

ANNEX: H

CERTIFICATE OF PRE-TENDER SITE INSPECTION



INTERNATIONAL RESCUE COMMITTEE, (IRC) INC.

Sudan Program

CERTIFICATE OF PRE-TENDER SITE INSPECTION

This is to Certify that Mr/Mrs/Ms/Eng.
of.....(Firm) on
..... (Date) carried out an inspection of the proposed site(s) of the Works to be
undertaken for Contract No.

This further certifies that the Tenderer is fully conversant with all Site conditions and information necessary for preparing the Tender and entering into a Contract for the completion of all Works according to the Specifications and the Programme for Work.

(Name):.....

(Signature):.....

(Designation):.....

duly authorized to sign Tenders on behalf of
.....

Date:.....

Note: This form should be competed and submitted with the Tender.